

WV58MR / WH58MR

Redundant rotary encoder with CANopen interface

User manual

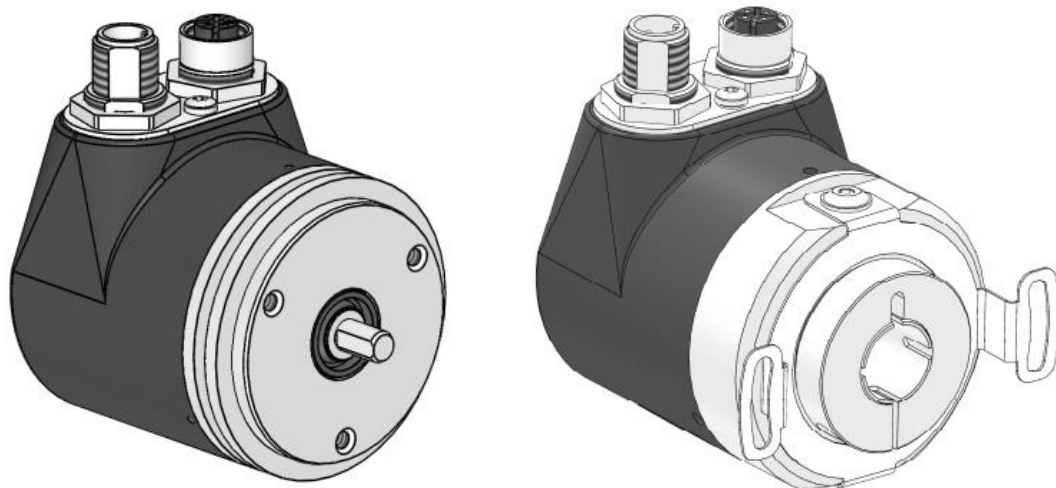

Table of contents

1	General Information	5
1.1	Documentation	5
1.1.1	History	5
1.2	Definitions	5
2	Intended use	5
2.1	Switching on the supply voltage	6
3	LED-signal.....	7
4	Functional description	9
4.1	Measuring range.....	9
4.2	Calibration	9
4.3	Reset to factory settings	9
5	Communication via CAN bus (CANopen)	9
5.1	Telegram structure.....	10
5.2	Node control.....	11
5.2.1	Network management (NMT) services	11
5.2.1.1	NMT communication states	12
5.2.1.2	Toggling between the NMT communication states	13
5.2.2	Boot-Up.....	13
5.2.3	SYNC object.....	13
5.3	Process data exchange	13
5.3.1	Transfer of process data objects (PDO)	13
5.3.1.1	Transmit PDO (from the WV58MR / WH58MR to the master)	14
5.4	Parameter data exchange.....	15
5.4.1	Transmission of Service Data Objects (SDO).....	15
5.4.1.1	Expedited Request/Response	15
5.4.1.2	Normal Request/Response.....	16
5.4.1.3	Error Response in SDO exchange	17
5.4.1.4	SDO examples	18
5.5	Node monitoring	20
5.5.1	Emergency Service (EMCY)	20
5.5.2	Node Guarding.....	20
5.5.3	Heartbeat	21
5.6	Layer Setting Service (LSS)	22
5.6.1	State change	23
5.6.1.1	Switch states of all LSS devices (Switch state global)	23
5.6.1.2	Switch states of individual LSS devices (Switch state selective).....	23
5.6.2	Configuration	24
5.6.2.1	Setting the node ID (Configure Node-ID)	24
5.6.2.2	Configuration of the baud rate (Configure bit timing parameters).....	25
5.6.2.3	Activate baud rate (Activate bit timing parameters)	26

5.6.2.4	Store configuration.....	26
5.6.3	Requesting parameters.....	27
5.6.3.1	Request Vendor ID.....	27
5.6.3.2	Request Product Code.....	27
5.6.3.3	Request revision number.....	27
5.6.3.4	Request serial number.....	28
5.6.3.5	Request Node ID.....	28
5.7	Directory of objects.....	29
5.7.1	Overview of objects.....	29
5.7.2	Object Description.....	31
5.7.2.1	1000h: Device Type.....	31
5.7.2.2	1001h: Error Register.....	31
5.7.2.3	1002h: Manufacturer Status Register.....	32
5.7.2.4	1003h: Pre-defined Error Field.....	32
5.7.2.5	1005h: COB-ID SYNC-message.....	33
5.7.2.6	1008h: Manufacturer Device Name.....	33
5.7.2.7	1009h: Manufacturer Hardware Version.....	33
5.7.2.8	100Ah: Manufacturer Software Version.....	34
5.7.2.9	100Ch: Guard Time.....	34
5.7.2.10	100Dh: Life Time Factor.....	34
5.7.2.11	1010h: Store Parameter.....	35
5.7.2.12	1011h: Restore Parameter.....	36
5.7.2.13	1014h: COB-ID Emergency message.....	38
5.7.2.14	1017h: Producer Heartbeat Time.....	39
5.7.2.15	1018h: Identity Object.....	39
5.7.2.16	1200h: Server SDO Parameter.....	40
5.7.2.17	1800h: 1. Transmit PDO Parameter.....	41
5.7.2.18	1801h: 2. Transmit PDO Parameter.....	42
5.7.2.19	1A00h: 1. Transmit PDO Mapping Parameter.....	44
5.7.2.20	1A01h: 2. Transmit PDO Mapping Parameter.....	44
5.7.2.21	2001h: Application offset.....	45
5.7.2.22	2002h: Calibrate encoder value.....	45
5.7.2.23	2003h: Limit speed low.....	46
5.7.2.24	2004h: Limit speed High.....	46
5.7.2.25	5000h: Diagnosis CAN Bus error.....	46
5.7.2.26	5F0Ah: Node-ID and baud rate Bus CAN.....	47
5.7.2.27	6000h: Operating Parameters.....	48
5.7.2.28	6001h: Measurement steps per revolution (Display per revolution = APU).....	48
5.7.2.29	6002h: Overall number of measurement steps.....	48
5.7.2.30	6003h: Preset value (calibration value).....	49
5.7.2.31	6004h: Position value.....	49
5.7.2.32	600Ch: Absolute accuracy.....	50
5.7.2.33	6030h: Velocity value.....	50
5.7.2.34	6031h: Speed parameters.....	50

5.7.2.35	6200h: Cycle timer.....	52
5.7.2.36	6400h: Operating range (Area state register).....	52
5.7.2.37	6401h: Work Area Low Limit.....	53
5.7.2.38	6402h: Work Area High Limit	54
5.7.2.39	6500h: Operating Status.....	55
5.7.2.40	6501h: Single-turn resolution.....	55
5.7.2.41	6502h: Number of distinguishable revolutions	56
5.7.2.42	6503h: Alarms.....	56
5.7.2.43	6504h: Supported Alarms.....	56
5.7.2.44	6505h: Warnings	57
5.7.2.45	6506h: Supported Warnings	57
5.7.2.46	6507h: Profile and Software Version	58
5.7.2.47	6508h: Operating Time	58
5.7.2.48	6509h: Offset value	58
5.7.2.49	650Ah: Module Identification.....	59
5.7.2.50	650Bh: Serial number.....	60
5.7.2.51	650Dh: Absolute accuracy.....	60
5.7.2.52	650Eh: Device functionality	60

1 General Information

1.1 Documentation

The following documents are associated with this product:

- Data sheet; it describes the technical data, the dimensions, the pin assignment, the accessories and the order key.
- Mounting instructions; they describe the mechanical and electrical installation with all safety-relevant conditions and the associated technical specifications.
- User manual; for commissioning the sensor and integrating it into a fieldbus system.
- EDS file (electronic data sheet); this file enables integration and configuration in a CANopen network by means of commercial CANopen configurators.

These documents can also be found at <http://www.siko-global.com/p/wv58mr>

and <http://www.siko-global.com/p/wh58mr>.

1.1.1 History

Change	Date	Description
099/22	May 16, 2022	Chapter 5.7.2.52 650Eh: Device functionality In line Default: CANopen Safety: 0013h (class 3 + CANopen Safety) omitted Chapter 1.1.1 History – new Supplements and corrections

1.2 Definitions

Decimal values are given as numbers without addition (e.g. 1234), except when indicated in direct connection with binary or hexadecimal values, In which case the extension d will be used (e.g. 1234d). Binary values are identified by adding b (e.g. 1011B) to the figures whereas hexadecimal values are extended by h (e.g. 280h).

2 Intended use

The WV58MR / WH58MR consists of two encoders, which collect redundantly absolute travel information. By means of the CANopen protocol, both encoders can be configured and read out via the CAN interface.

Both encoders are equipped with 3 LEDs (yellow, red, green), which indicate error or status information for diagnostic purposes.

The rotary encoder WV58MR / WH58MR is designed for redundant position and speed detection. It can be used for applications up to Performance Level D (PLd) in the overall system. For this purpose an overriding safe encoder evaluation device is required. Since the encoder is incapable with its encoder-internal diagnostic function to initiate actions such as

obtaining a safe state on its own. Increased demands are placed on the electrical and mechanical connection of the rotary encoder.

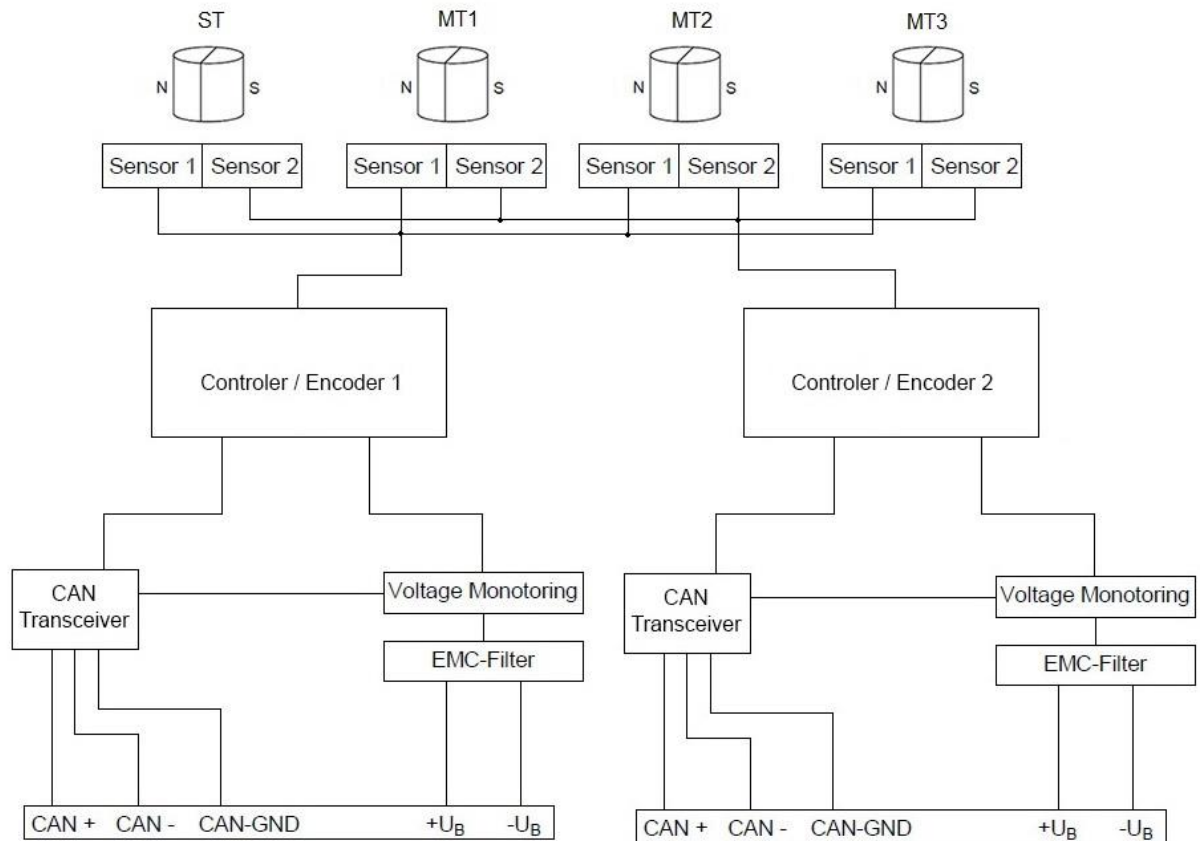

Fig. 1: Block diagram

2.1 Switching on the supply voltage

WV58MR / WH58MR initializes after being switched on. During initialization, the LEDs light up one after the other and the configuration parameters are loaded from the non-volatile memory to the random memory of the controller.

Each sensor will work with its default values as long as no changes have been made to it. With parameters changed, the sensor will work with the changed data, *which must be stored if they are intended to be used after power off/on*.

After completing the initialization procedure, each sensor sends a specific NMT command, the boot-up message, which informs the system about their availability. The WV58MR / WH58MR is now in the pre-operational mode. In this state, the encoder can be parameterized via SDO commands in accordance with the requirements of the application. This applies to configuration parameters of the sensor unit as well as to the way it makes available to the system its position values (asynchronous or synchronous data transmission).

3 LED-signal

Each transmitter has 3 LEDs in the colors yellow, green and red for diagnosis and status purposes.

- A yellow LED for device-specific states
- A green LED for indicating the NMT status or the LSS configuration status (CAN Run LED)
- A red LED for CAN error states or for indicating the LSS configuration status (CAN Err LED)

The LSS waiting status is not indicated via the LEDs.

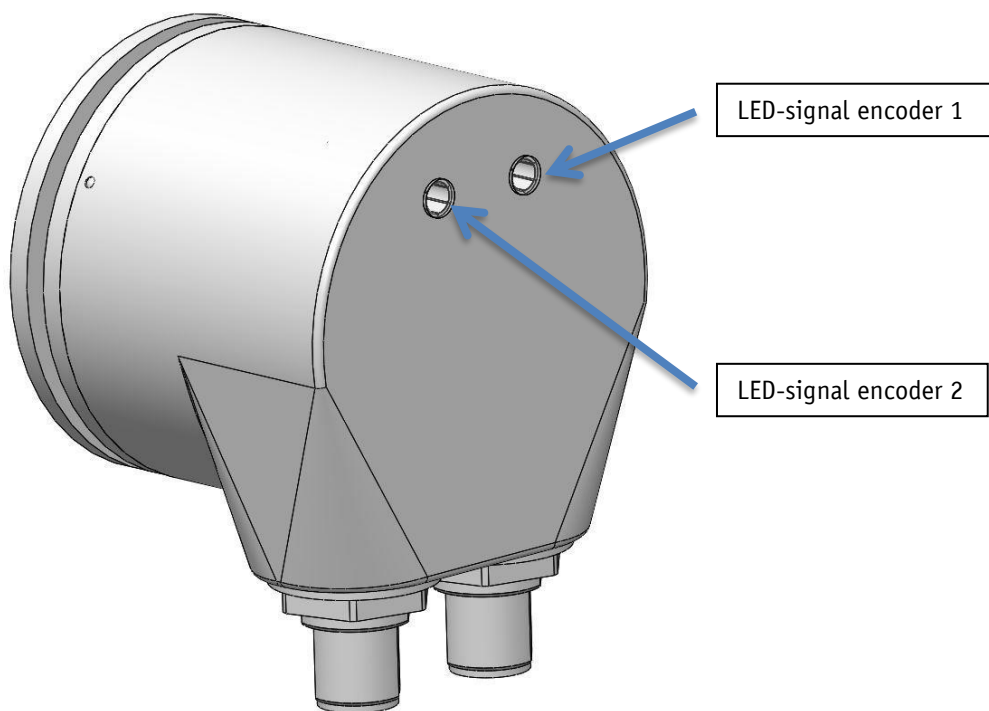

Fig. 2: LED-signal

Device-specific diagnosis

Error status	LED status
Maximum speed exceeded	On
encoder is in the valid speed range	Off

Table 1: Device-specific status LED

CAN diagnosis:

The CiA DS-303 Part 3 V1.4.0 indicator specification is the basis of the CAN diagnosis

LED status	Description
On	LED is permanently on
Off	LED is permanently off

LED status	Description
Flickering	Both LEDs alternately with the frequency of 10 Hz (50 ms on/off)
Flashing	LED flashes at a frequency of 2.5 Hz (200 ms on/off)
Single Flash	LED is 200 ms on, 1000 ms off
Double Flash	LED is 200 ms on, 200 ms off, 200 ms on, 1000 ms off

Table 2: CAN LED statuses acc. to CiA DS-303

CAN Run LED:

NMT state	LED status
Pre-Operational	Flashing
Operational	On
Stopped	Single Flash

Table 3: CAN Run LED

CAN Err LED:

Error states	LED status
No error	Off
Warning limit reached (at least one error counter (Transmit Error Counter CANTEC or Receive Error Counter CANREC) of the CAN controller has reached or exceeded the warning limit (too many error frames).	Single Flash
Error control event => A Guard Event (if no RTR Node guard received from master within the lifetime set)	Double Flash
Bus off	On

Table 4: CAN Err LED

CAN Run LED and CAN Err LED alternately:

LSS state	LED status
configuration	Flickering

Table 5: LSS configuration

4 Functional description

4.1 Measuring range

The measuring range depends on the chosen device design and the APU set.

Design	Default measuring range	With changed APU (Object 6001h)
Singleturn	0...16383	$0 \dots ((\text{APU} * 1) - 1)$
4 Bit Multiturn	0...262143	$0 \dots ((\text{APU} * 16) - 1)$
8 Bit Multiturn	0...4194303	$0 \dots ((\text{APU} * 256) - 1)$
12 Bit Multiturn	0...67108863	$0 \dots ((\text{APU} * 4096) - 1)$

Counting direction:

The encoder delivers ascending position values when the shaft is rotated clockwise (CW, view on the shaft). This property can be changed via Object [6000h: Operating Parameters](#)

4.2 Calibration

Owing to the absolute system, calibration is required only once when the system is taken into operation and can be performed at any position. This enables alignment of the encoder zero point with the system's mechanical zero point. With calibration, the calibration value is adopted for calculation of the position value. The resulting offset value is output in Object [6509h: Offset value](#). The following equation is applied in case of calibration:

Position value = 0 + calibration value + application offset

4.3 Reset to factory settings

To return to the original condition of the device as delivered, there exist the following options:

Access	Coding	Settings are restored	
CANopen (see Object 1011h: Restore Parameter)	1011h "load"	Sub-index 1	All parameters
		Sub-index 2	Only bus parameters
		Sub-index 3	Only CiA DS-406 parameters
		Sub-index 4	Only manufacturer-specific parameters

Table 6: Access to factory settings

5 Communication via CAN bus (CANopen)

The CANopen communication profile CiA DS-301 V4.2, the Device profile for Encoders CiA DS-406 V3.2 as well as the indicator specification CiA DS-303 Part 3 V1.4.0 for CAN diagnosis form the basis for the WV58MR / WH58MR. The WV58MR / WH58MR supports device class C2. The details required for a better understanding of the operation are included in this

documentation. If more in-depth information is required, we recommend the applicable technical literature on CAN or Canopen.

5.1 Telegram structure

The data telegram of a CAN message consists of the following fields:

SOF:	Identifier (COB-ID)	Control field:	Data field (max. 8 byte)	CRC	ACK/EOF:
------	---------------------	----------------	--------------------------	-----	----------

SOF:

Start of Frame start bit of the telegram

Identifier (COB-ID):

- By means of the identifier, all bus subscribers check whether the message is relevant for each of them.
- The identifier determines the priority of the message. The lower the value of the identifier, the higher is the priority of the message. This enables preferential transmission of important messages via the bus.

The Identifier field contains the identifier as well as bits for the recognition of the length of the identifiers (11 or 29 bits). The device address, channel selection as well as data direction are determined via the identifier as well.

Thus, the 11bits identifier (COB identifier) consists of a 4bit function code and a 7bit node number.

Bit no.	10	9	8	7	6	5	4	3	2	1	0
Type	Functional code				Node number (Node ID)						
Assignment	x	x	x	x	0	0	x	x	x	x	X

The following functional codes have been defined in the "Pre-defined Connection Set" (only the functional codes used in the present device are shown):

Object	Functional code	Resulting COB-ID	Object	Page
Network management (NMT)	0000b	0	-	11
SYNC message	0001b	128d (80h)	1005h	33
Emergency message	0001b	128d (80h) + Node-ID	1014h	38
TPD01	0011b	384d (180h) + Node-ID	1800h	41
TPD02	0101b	640d (280h) + Node-ID	1801h	42
SDO (tx)	1011b	1408d (580h) + Node-ID	1200h	40
SDO (rx)	1100b	1536d (600h) + Node-ID	1200h	40
Heartbeat message	1110b	1792d (700h) + Node-ID	-	21
Node Guard message	1110b	1792d (700h) + Node-ID	-	20
LSS (tx)	-	2021d (7E4h)	-	22
LSS (rx)	-	2020d (7E5h)	-	22

Table 7: Overview of COB identifiers

Changes to COB IDs are only possible in the PRE-OPERATIONAL NMT status. First, the COB ID must be switched invalid via bit 31 = 1b before it can be changed and reactivated. The COB ID of the Sync object is an exception, where bit 30 must be = 0b to enable the COB ID to be changed. As bit 30 cannot be set to 1b in the WV58MR / WH58MR, the COB ID could be changed at any time.

The node number (Node ID) (see also object [5F0Ah: Node-ID and baud rate Bus CAN](#)) is assigned once in every bus system with configuration of the master on WV58MR / WH58MR. The node numbers range from 1 to 127. Node ID = 0 is reserved and must not be used.

The adoption of a node ID or baud rate which was reset occurs only after re-initialization (see chapter [5.2.1: Network management \(NMT\) services](#)).

With the WV58MR / WH58MR rotary encoder, an encoder with the node ID 1 (1h) and the redundant encoder with the node ID 2 (2h) is delivered ex works.

Control field:

contains bit-by-bit information concerning the number of user data and determines whether a data frame or RTR frame (Remote Transmission Request frame) is concerned.

Data field:

contains up to 8 bytes of user data. The user data has a different meaning depending on the channel selection.

CRC:

contains bits for error detection.

ACK/EOF:

The ACK/EOF field contains telegram acknowledgment bits as well as bits for determining the end of telegram.

For a detailed description of the telegram please refer to the applicable technical CAN literature. For simplification, only identifier (COB ID) and data field will be dealt with in the subsequent telegram descriptions.

5.2 Node control

5.2.1 Network management (NMT) services

The master configures, manages and monitors network nodes via the NMT service. The device is always in one of the four communication states "INITIALIZATION", "PRE-OPERATIONAL", "OPERATIONAL" or "STOPPED" (see [Fig. 3](#))

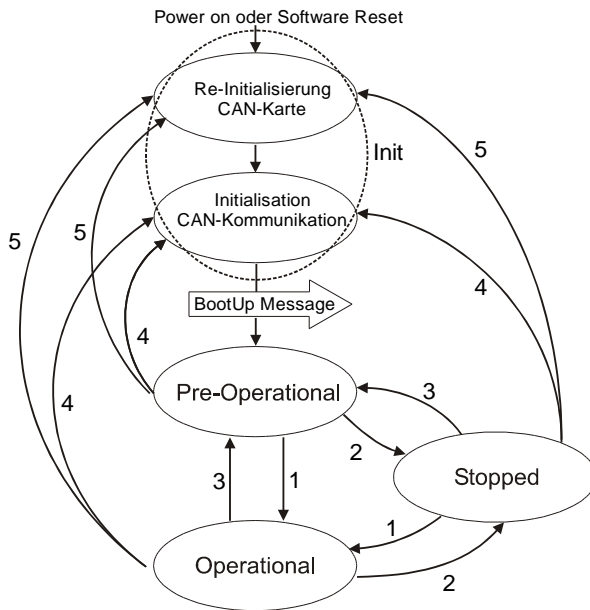

Fig. 3: NMT Status diagram

5.2.1.1 NMT communication states

NMT Status 'INITIALIZATION'

The device is not involved in the bus actions in this state. All hardware and software components are initialized. This state is attained after switching on the device or after receipt of the command code 81h ("Reset node") of the own or global addresses. Following receipt of the command code 82h ("Reset Communication"), the display will enter the initialization stage as well. But only hardware and software associated with CAN communication will be reinitialized. The device signals automatically the completion of initialization by sending a boot-up message. As soon as the boot-up message was sent successfully, the device will enter the "PRE-OPERATIONAL" status.

NMT Status PRE-OPERATIONAL

Parameterization data (SDO) can be exchanged in the pre-operational mode. However, no process data (PDO's) is transferred.

NMT Status OPERATIONAL

The exchange of process data is enabled as well. However, COB-ID and Transmit PDO Mapping parameters can no longer be changed in this status.

NMT Status STOPPED

Communication is stopped except for heartbeat and node guarding Only NMT communication is enabled.

5.2.1.2 Toggling between the NMT communication states

For toggling between the communication states, telegrams with the following structures are used

Change of state		Transition in Fig. 3	COB- ID	Com- mand	Node ID
from	to				
PRE-OPERATIONAL / STOPPED	OPERATIONAL	1d	0h	01h	x
OPERATIONAL/ PRE- OPERATIONAL	STOPPED	2d	0h	02h	x
OPERATIONAL / STOPPED	PRE-OPERATIONAL	3d	0h	80h	x
OPERATIONAL / PRE- OPERATIONAL / STOPPED	INITIALIZATION (Reset Node)	5d	0h	81h	x
OPERATIONAL / PRE- OPERATIONAL / STOPPED	INITIALIZATION (Reset Communication)	4d	0h	82h	x

Table 8: Toggling between communication states

If x = 0h is transferred as node ID, then the message is intended for all bus subscribers

5.2.2 Boot-Up

The COB ID of the boot-up message is made up of 700h and the node ID. The "Initialization" NMT status is output as data content.

COB-ID	Byte 0
700h + Node-ID	00h

Table 9: Boot-Up message

5.2.3 SYNC object

CANopen enables the simultaneous query of all inputs and the simultaneous setting of all outputs. The synchronization message (SYNC), a CAN message with high priority serves this purpose. The identifier of the Sync object can be set via object 1005h (see [1005h: COB-ID SYNC-message](#)).

5.3 Process data exchange

5.3.1 Transfer of process data objects (PDO)

Process data objects (PDO) serve for fast exchange of process data. A maximum of 8 bytes of user data can be transferred in a PDO. The WV58MR / WH58MR supports the Transmit PDO services TPD01 and TPD02 according to CiA DS-301 and CiA DS-406.

5.3.1.1 Transmit PDO (from the WV58MR / WH58MR to the master)

PDO transfer from the encoder to the bus master (TPDO) can be initiated as a result of various events:

- asynchronous, controlled by an internal device timer
- synchronous as a response to a SYNC telegram
- as a response to an RTR message

TPDO1 and TPDO2 are generated from the position value and the speed value. The transfer behavior of TPDO1 is determined via the objects 1800h, 1A00h and 6200h and is assigned to asynchronous transmission. TPDO2 is defined via the objects 1801h and 1A01h and serves synchronous transmission. Assignment is static and cannot be changed.

Messages are structured as shown in [Table 10](#).

COB-ID	Process data in binary code					
	Byte 0 (LSB)	Byte 1	Byte 2	Byte 3 (MSB)	Byte 4 (LSB)	Byte 5 (MSB)
TPDO1 180h + Node-ID	Position value				Speed value	
TPDO2 280h + Node-ID						

Table 10: TPDO message

Asynchronous data transmission (TPDO1)

If a TPDO1 is to be sent cyclically, then the cycle time must be entered in milliseconds into object 1800h, sub-index 05h. The TPDO1 will not be sent if the value 0 ms is written. The function is disabled. The minimum value to be set is 1 (= 1 ms). Alternately, the value can also be written into the permanently internally linked object 6200h.

Synchronous data transfer (TPDO2)

As delivered, the device responds to every SYNC Message received with the output of the TPDO2 message. 1h is entered for synchronous transmission in object 1801h, sub-index 02h. If a value n is entered between 1d and 240d (= F0h), the device will respond to every nth SYNC message.

RTR

Queries can be sent via RTR (see chapter [5.1: Telegram structure](#), control field) to TPDO1 and TDPO2.

5.4 Parameter data exchange

5.4.1 Transmission of Service Data Objects (SDO)

Service data objects serve mainly device configuration via the directory of objects. SDOs in the expedited Request/Response and in the normal normal Request/Response are supported. The identifier is set to 11 bits and cannot be changed.

Two SDO services are available:

- SDO (rx) (Master → WV58MR / WH58MR): 600h + Node-ID
- SDO (tx) (WV58MR / WH58MR → Master): 580h + Node-ID

These SDO identifiers cannot be changed!

5.4.1.1 Expedited Request/Response

Except for reading the object [1008h: Manufacturer Device Name](#), all SDOs are exchanged between two subscribers in the expedited Request/Response method. The user data is provided already with the initialization message.

SDO messages are set up as follows:

COB-ID	User data in binary code							
	Byte 0 <small>0_{SEP}</small> (read / write)	Byte 1 LSB	Byte 2 (MSB)	Byte 3	Byte 4 LSB	Byte 5	Byte 6	Byte 7 (MSB)
SDO rx/tx + Node-ID	Command byte	Index		Sub-index	User data (Parameter)			

Command byte, byte 0:

The command byte determines the type of access and the number of valid data bytes. The following command bytes are valid for the WV58MR / WH58MR:

Command byte	Type	Function
Write Request	23h	SDO (rx), Initiate Download Request, expedited Send parameter to slave (All 4 data bytes valid)
Write Request	2Bh	SDO (rx), Initiate Download Request, expedited Send parameter to slave (2Bytes of 4 data bytes valid)
Write Request	2Fh	SDO (rx), Initiate Download Request, expedited Send parameter to slave (1Byte of 4 data bytes valid)
Write Response	60h	SDO (tx), Initiate Download Response Acknowledgment of data acquisition to master
Read Request	40h	SDO (rx), Initiate Upload Request Request parameter from slave
Read Response	43h	SDO (tx), Initiate Upload Response, expedited Report parameter to master (All 4 data bytes valid)
Read Response	4Bh	SDO (tx), Initiate Upload Response, expedited Report parameter to master (2Bytes of 4 data bytes valid)

Command byte		Type	Function
Read Response	4Fh	SDO (tx), Initiate Upload Response, expedited	Report parameter to master (1Byte of 4 data bytes valid)
Error Response	80h	SDO (tx), Abort Domain Transfer	Slave reports error code to master

Table 11: Command coding

Index, bytes 1 and 2:

The index (object number) is entered in the user data byte 2 (low byte) and user data byte 3 (high byte) in the Intel data format. Here, the index of the object to be parameterized is entered.

Sub-index, Byte 3:

The sub-index indicates the number of the fields for objects realized as an array.

User data (parameters), byte 4-7:

In the user data, the value of the parameter is entered in left-aligned Intel notation. Byte 4 = Low-Byte ... Byte 7 = High-Byte

5.4.1.2 Normal Request/Response

If more than 4 bytes of service data are to be transferred, the data is exchanged between two subscribers via the normal Request/Response. This procedure is also initiated by an initialization message, and the actual user data will be transferred in the subsequent segment messages.

For the WV58MR / WH58MR this is only the case with reading of the object [1008h: Manufacturer Device Name](#).

The initialization message has the following structure:

COB-ID	User data in binary code							
	Byte 0 _{SEP} (read / write)	Byte 1 LSB	Byte 2 (MSB)	Byte 3	Byte 4 LSB	Byte 5	Byte 6	Byte 7 (MSB)
SDO rx/tx + Node-ID	Command byte	index		Sub-index	User data (number of user data)			

The segment message has the following structure:

COB-ID	User data in binary code							
	Byte 0 _{SEP} (read / write)	Byte 1 LSB	Byte 2	Byte 3	Byte 4	Byte 5	Byte 6	Byte 7 (MSB)
SDO rx/tx + Node-ID	Command byte	User data						

Initialization and segment message: Command byte, byte 0:

The command byte determines the type of access and the number of valid data bytes. The following command bytes are valid for the WV58MR / WH58MR:

Command byte		Type	Function
Read Request	40h	SDO (rx), Normal Initiate Upload Request	Request parameter from slave (number of bytes to be transferred).
Read Request	60h	SDO (rx), Normal Segment Upload Request	Request parameter from slave (user data)
Read Response	41h	SDO (tx), Normal Initiate Upload Response	Report parameter to master (number of bytes to be transferred).
Read Response	03h	SDO (tx), Normal Segment Upload Response	Report parameter to master (user data)
Error Response	80h	SDO (tx), Abort Domain Transfer	Slave reports error code to master

Table 12: Command coding

Initialization message: Index, bytes 1 and 2:

The index (object number) is entered in the user data byte 2 (low byte) and in the user data byte 3 (high byte) in the Intel data format. Here, the index of the object to be parameterized is entered.

Initialization message: Sub-index, Byte 3:

The subindex indicates the number of the fields for objects realized as an array.

Initialization message: User data (parameters), byte 4-7:

In the service data range, the value of the parameter is entered in left-aligned Intel notation. Byte 4 = Low-Byte ... Byte 7 = High-Byte

Segment message: User data (parameters), byte 1-7:

In the user data range, the value of the parameter is entered in left-aligned Intel notation. Byte 1 = Low-Byte ... Byte 7 = High-Byte

5.4.1.3 Error Response in SDO exchange

With invalid access, an error message (Abort) is returned to the master. The error codes are described in the CANopen profile (CiA DS-301) or in the encoder profile (CiA DS-406), respectively. The table below shows the error codes used:

Error code	Description
05030000h	Toggle bit in Normal Transfer of Request/Response unequal.
06010000h	Wrong access to an object.
06010001h	Read access to Write-Only

Error code	Description
06010002h	Write access to Read-Only.
06020000h	Object doesn't exist in the object directory.
06090011h	Sub-index does not exist
06090030h	Wrong value range of selected parameter.
08000020h	Parameters cannot be transferred to application or stored.
08000022h	Parameters cannot be transferred to application or stored due to the current device status.
08000024h	No data available

Table 13: Error codes

5.4.1.4 SDO examples

Example of reading SDO parameters with the expedited Request/Response:

The calibration value stored in object 6003 of the directory of objects is to be read from the slave with device address 1h.

Calculation of the identifier: $600h + \text{Node-ID} = 600h + 1h = 601h$

Command: 40h

index: 6003h

sub-index: 00h

The current value is $510d = 01FEh$

Request of master from slave with node ID 1h:

COB-ID	User data							
	Command	Index L	Index H	Sub-index	Data 0	Data 1	Data 2	Data 3
601h	40h	03h	60h	00h	x	x	x	x

Response to the request by the slave

Calculation of the identifier: $580h + \text{Node-ID} = 581h$

COB-ID	User data							
	Command	Index LB	Index HB	Sub-index	Data 0	Data 1	Data 2	Data 3
581h	43h (4 bytes valid)	03h	60h	00h	FEh	01h	00h	00h

Example of writing SDO parameters with the expedited Request/Response:

The calibration value stored with 2 bytes in object 6003h of the directory of objects is to be changed in the slave with device address 1h.

Calculation of the identifier: $600h + \text{Node-ID} = 600h + 1h = 601h$

Command: 2 bytes are to be written 2Bh

Index: 6003h

Sub-index: 00h

The new value shall be $4500d = 1194h$

Writing of a value from master to slave with node ID 1h:

COB-ID	User data							
	Command	Index L	Index H	Sub-index	Data 0	Data 1	Data 2	Data 3
601h	2Bh (2 bytes valid)	03h	60h	00h	94h	11h	00h	00h

Response to the command by the slave:

Calculation of the identifier: $580h + \text{Node-ID} = 580h + 1h = 581h$

COB-ID	User data							
	Command	Index L	Index H	Sub-index	Data 0	Data 1	Data 2	Data 3
581h	60h	03h	60h	00h	00h	00h	00h	00h

Example of reading SDO parameters with normal Request/Response:

The manufacturer device name stored in object 1008h of the directory of objects is to be read from the WV58MR / WH58MR with device address 1h.

Calculation of the identifier: $600h + \text{Node-ID} = 600h + 1h = 601h$

Command: 40h

Index: 1008h

Sub-index: 00h

First request (= initialization) of master from slave with node ID 1h:

COB-ID	User data							
	Command	Index L	Index H	Sub-index	Data 0	Data 1	Data 2	Data 3
601h	40h	08h	10h	00h	x	x	x	x

Response to the request by the slave

Calculation of the identifier: $580h + \text{Node-ID} = 581h$

COB-ID	User data							
	Command	Index LB	Index HB	Sub-index	Data 0	Data 1	Data 2	Data 3
581h	41h	08h	10h	00h	06h	00h	00h	00h

Number of expected user data bytes: 6

Second request of master from slave with node ID 1h:

COB-ID	User data							
	Command	Index L	Index H	Sub-index	Data 0	Data 1	Data 2	Data 3
601h	60h	08h	10h	00h	x	x	x	x

Response to the request by the slave

COB-ID	User data							
	Command	Data 0	Data 1	Data 2	Data 3	Data 4	Data 5	Data 6
581h	03h	57h ("W")	56h ("V")	35h ("5")	38h ("8")	4Dh ("M")	52h ("R")	00h -

5.5 Node monitoring

5.5.1 Emergency Service (EMCY)

In the case of an error, the status of the bus subscriber is transferred via high-priority emergency messages (emergency telegrams). These messages have a data length of 8 bytes and contain error information.

The emergency message is transferred as soon as a sensor or communication error has occurred or when such errors have been corrected. The cause of the error is deposited in the error buffer (see object [1003h: Pre-defined Error Field](#)). An emergency object is sent only once per error event. Removal of the cause of the error is signaled by sending an emergency message with the error code 0000h (no error). If multiple errors have occurred and one cause of error is removed, the error code 0000h is output as well; the persisting error status is indicated in the error register, however.

Identifier	Byte 0	Byte 1	Byte 2	Byte 3	Byte 4	Byte 5	Byte 6	Byte 7
11/ 29 Bit	Emergency Error Code		Error Register (Object 1001h)	Manufacturer-specific error field (not used)				

Emergency Error Code

Error Description	Error Code
Cause of the error removed	0000h
Bus status changed over to the error passive mode	8120h
recovered from Bus Off	8140h
Manufacturer-specific Position value error	FF05h
Manufacturer-specific Velocity error	FF12h
Manufacturer-specific Error limit speed low	FF13h
Manufacturer-specific Error limit speed high	FF14h
Manufacturer-specific Position error work area 1	FF15h
Manufacturer-specific Position error work area 2	FF16h

Table 14: Emergency Error Code

The identifier of the emergency object is set to 80h + node ID by default; however, it can be changed via object 1014h (see [1014h: COB-ID Emergency message](#)). Transmission of an emergency message is enabled in the NMT statuses "OPERATIONAL" or "PRE-OPERATIONAL" only! Transmission of the emergency messages can be disabled by setting the COB-ID Valid bit to 1.

5.5.2 Node Guarding

Node guarding is available for failure monitoring of the CANopen network. During node guarding, the master transmits remote frames (RTR, remote transmit request, message request telegrams) on the guarding identifiers of the nodes to be monitored. The latter respond with the guarding message. This message contains the current NMT status of the node as well as a toggle bit whose value must change after each message. The master assumes that a node error has occurred if status or toggle bits do not correspond with those expected by the master or if there is no response.

Via objects 100Ch (Guard Time) and 100Dh (Life Time Factor) the time interval (Life-Time) is set within which the NMT master expects to receive a response. The time interval "Life Time" is calculated from the cycle time "Guard Time", multiplied with the factor "Life Time Factor". If the NMT master does not receive a response to its RTR frame within the "Life Time", it may react with suitable measures. Upon switching on, node guarding will be enabled by sending the first RTR frame of the master to the slave. Node Guarding is deactivated if the value of either object (100Ch or 100Dh) is set to 0h.

The answer of the node to the RTR frame of the master is formed as follows:

Identifier	Byte 0	
700h + Node-ID	Bit 7: Toggle Bit	Bit 6 ... 0 NMT state

Toggle Bit:

The toggle bit must alternate between two subsequent responses of the device. After the guarding protocol has been enabled, the toggle bit must have the value 0 with the first response.

NMT state:

4: STOPPED

5: OPERATIONAL

127: PRE-OPERATIONAL

The identifier of the node guarding protocol is permanently set to 700h + Node ID and cannot be changed. A node guard message can be sent in the NMT statuses "OPERATIONAL", "PRE-OPERATIONAL" or "STOPPED".

Note:

Literature recommends heartbeat to be used for node monitoring. Only the master can detect missing communication via the node guarding protocol as opposed to the heartbeat that can be received by all subscribers.

5.5.3 Heartbeat

The master monitors the state of the slave device via Heartbeat protocol. While doing this, the device sends independently its NMT status cyclically. The WV58MR / WH58MR is a heartbeat producer, it does not receive nor process heartbeat protocols itself. The cycle time of the heartbeat message is set via object 1017h. The heartbeat protocol is deactivated if the cycle time is 0h.

The heartbeat message consists of the COB ID and an additional byte. In this byte, the current NMT state is deposited.

COB-ID	Byte 0
700h + Node-ID	NMT state

NMT state:

4: STOPPED

5: OPERATIONAL

127: PRE-OPERATIONAL

The identifier of the heartbeat protocol is permanently set to 700h + Node ID and cannot be changed. Heartbeat messages are sent in the NMT statuses "OPERATIONAL", "PRE-OPERATIONAL" or "STOPPED".

5.6 Layer Setting Service (LSS)

Layer Setting Service (LSS) is a special method described in CiA DS-305it serves for retrieving and configuring various parameters (node ID, baud rate, and Identity Object 1018h).

Every device must have a unique LSS number composed of the entries in Object 1018h.

- Vendor ID: 0000 0195h
- Product Code: FFFF FFFFh
- Revision number: FFFF FFFFh
- Serial number: xxxx xxxxh (serial number of the encoder concerned)

In order to enable the use of full LSS functionality, all devices on the bus must support the LSS method. An LSS master must exist and all nodes must start with the same baud rate. After starting, the device will be in the LSS waiting state. To enable configuration, one or all devices must be switched to the LSS configuration state. If the LSS master expects to receive an answer to its command, only one LSS slave must be switched to the LSS configuration mode. If an encoder is in the LSS configuration mode, this will be indicated via the green and red LEDs (see chapter 3 LED-signal).

Two LSS services are available:

- LSS (rx) (LSS Master → WV58MR / WH58MR): 7E5h
- LSS (tx) (WV58MR / WH58MR → LSS Master): 7E4h

These LSS identifiers cannot be changed!

A message consists always of 8 bytes. Byte 0 contains the command (Command – Specifier cs), followed by max. 7 data bytes Unused data bytes are reserved and must be filled with 00h.

Services	LSS waiting	LSS configuration
Switch state global	yes	yes
Switch state selective	yes	no
Activate bit timing parameters	no	Yes, if all devices on the bus support LSS
Configure bit timing parameters	no	yes
Configure node-ID	no	yes
Store configuration	no	yes
Request LSS address	no	yes
Request Node ID	no	yes

Table 15: State behavior of the supported LSS services

5.6.1 State change

5.6.1.1 Switch states of all LSS devices (Switch state global)

With this command, all devices on the bus can be set to the LSS Waiting or LSS Configuration states. The LSS slave devices do not respond.

Master → all LSS slaves

COB-ID	User data							
	Byte 0 Command	Byte 1	Byte 2	Byte 3	Byte 4	Byte 5	Byte 6	Byte 7
7E5h	04h	Mode	00h	00h	00h	00h	00h	00h

Mode:

00h: Switch to LSS waiting state

01h: Switch to LSS configuration state

5.6.1.2 Switch states of individual LSS devices (Switch state selective)

With this command, Individual LSS slave devices can be set to the LSS Configuration state via the unique LSS number.

Master → WV58MR / WH58MR

COB-ID	User data							
	Byte 0 Command	Byte 1	Byte 2	Byte 3	Byte 4	Byte 5	Byte 6	Byte 7
7E5h	40h	Vendor ID				00h	00h	00h

COB-ID	User data							
	Byte 0 Command	Byte 1	Byte 2	Byte 3	Byte 4	Byte 5	Byte 6	Byte 7
7E5h	41h	Product Code				00h	00h	00h

COB-ID	User data							
	Byte 0 Command	Byte 1	Byte 2	Byte 3	Byte 4	Byte 5	Byte 6	Byte 7
7E5h	42h	Revision number				00h	00h	00h

COB-ID	User data							
	Byte 0 Command	Byte 1	Byte 2	Byte 3	Byte 4	Byte 5	Byte 6	Byte 7

7E5h	43h	Serial number	00h	00h	00h
------	-----	---------------	-----	-----	-----

WV58MR / WH58MR → Master

COB-ID	User data							
	Byte 0 Command	Byte 1	Byte 2	Byte 3	Byte 4	Byte 5	Byte 6	Byte 7
7E4h	44h	00h	00h	00h	00h	00h	00h	00h

5.6.2 Configuration

5.6.2.1 Setting the node ID (Configure Node-ID)

The LSS master can set the node ID of individual nodes to configuration mode in order to configure the LSS slave. If the new node ID is intended to still be available after Power off/on, the "Save configuration" command must be output after the change. For immediate activation of the new node ID, the LSS slave must be set to the LSS Waiting mode, followed by an NMT "Reset Communication" 82h. Another possibility would be to execute power off/on after "Save configuration".

Master → WV58MR / WH58MR

COB-ID	User data							
	Byte 0 Command	Byte 1	Byte 2	Byte 3	Byte 4	Byte 5	Byte 6	Byte 7
7E5h	11h	NID	00h	00h	00h	00h	00h	00h

NID:

01h ... 7Fh: Node ID

WV58MR / WH58MR → Master

COB-ID	User data							
	Byte 0 Command	Byte 1	Byte 2	Byte 3	Byte 4	Byte 5	Byte 6	Byte 7
7E4h	11h	Error Code	Spec error	00h	00h	00h	00h	00h

Error Code:

00h: Transmission successful

01h: no valid node ID

FFh: Implementation error see Spec error

Spec error:

This byte is nonzero only in case of an implementation error and Error Code FFh

5.6.2.2 Configuration of the baud rate (Configure bit timing parameters)

The baud rate of a single or of multiple LSS slaves can be configured via this command. If the new baud rate is intended to still be available after Power off/on, the "Save configuration" command must be output after the change. To activate the new baud rate the [5.6.2.3 Activate baud rate \(Activate bit timing parameters\)](#) command must be output and the LSS slave set to the LSS Waiting state. Another possibility of activating the new baud rate would be to execute power off/on after "Save configuration".

Master → WV58MR / WH58MR

COB-ID	User data							
	Byte 0 Command	Byte 1	Byte 2	Byte 3	Byte 4	Byte 5	Byte 6	Byte 7
7E5h	13h	Table selector	Table index	00h	00h	00h	00h	00h

Table selector:

00h: CiA DS-301 bit timing Table

80h...FEh: Manufacturer-specific bit timing Table

Table index:

Table index	Baud rate
0	1000 kbit/s
1	800 kbit/s
2	500 kbit/s
3	250 kbit/s
4	125 kbit/s
5	reserved
6	50 kbit/s
7	20 kbit/s
8	not supported
9	not supported

The device supports only Table selector 00h and Table index 0 until 7.

WV58MR / WH58MR → Master

COB-ID	User data							
	Byte 0 Command	Byte 1	Byte 2	Byte 3	Byte 4	Byte 5	Byte 6	Byte 7
7E4h	13h	Error Code	Spec error	00h	00h	00h	00h	00h

Error Code:

00h: Transmission successful

01h: no valid baud rate

FFh: Implementation error see Spec error

Spec error:

This byte is nonzero only in case of an implementation error and Error Code FFh

5.6.2.3 Activate baud rate (Activate bit timing parameters)

This command activates the new baud rate set via [5.6.2.2 Configuration of the baud rate \(Configure bit timing parameters\)](#) without requiring Power off/on.

Master → WV58MR / WH58MR

COB-ID	User data							
	Byte 0 Command	Byte 1 LSB	Byte 2 MSB	Byte 3	Byte 4	Byte 5	Byte 6	Byte 7
7E5h	15h	Switch delay		00h	00h	00h	00h	00h

Switch Delay:

The Switch delay parameter defines the length of two delay periods (d1, d2) of the same length and must correspond with a multiple of 1 ms. After expiry of the individual processing time and delay time d1, the new baud rate will be adopted internally. After expiry of the delay time d2, the LSS slave will report with the boot up via the newly set baud rate. This procedure prevents the synchronous presence on the bus of devices with different baud rates. The LSS slave cannot send messages during the two delay periods d1 and d2.

5.6.2.4 Store configuration

This command must only be executed if only one LSS slave is in the configuration mode. The current settings will be stored subsequently.

Master → WV58MR / WH58MR

COB-ID	User data							
	Byte 0 Command	Byte 1	Byte 2	Byte 3	Byte 4	Byte 5	Byte 6	Byte 7
7E5h	17h	00h	00h	00h	00h	00h	00h	00h

WV58MR / WH58MR → Master

COB-ID	User data							
	Byte 0 Command	Byte 1	Byte 2	Byte 3	Byte 4	Byte 5	Byte 6	Byte 7
7E4h	17h	Error Code	Spec error	00h	00h	00h	00h	00h

Error Code:

00h: Transmission successful

01h: Store configuration is not supported

02h: Error occurred during storing

FFh: Implementation error see Spec error

Spec error:

This byte is nonzero only in case of an implementation error and Error Code FFh

5.6.3 Requesting parameters

The following requests must only be executed if only one LSS slave is in the configuration mode.

5.6.3.1 Request Vendor ID

Master → WV58MR / WH58MR

COB-ID	User data							
	Byte 0 Command	Byte 1	Byte 2	Byte 3	Byte 4	Byte 5	Byte 6	Byte 7
7E5h	5Ah	00h	00h	00h	00h	00h	00h	00h

WV58MR / WH58MR → Master

COB-ID	User data							
	Byte 0 Command	Byte 1 LSB	Byte 2	Byte 3	Byte 4 MSB	Byte 5	Byte 6	Byte 7
7E4h	5Ah	Vendor ID (see Object 1018.1h)			00h	00h	00h	

5.6.3.2 Request Product Code

Master → WV58MR / WH58MR

COB-ID	User data							
	Byte 0 Command	Byte 1	Byte 2	Byte 3	Byte 4	Byte 5	Byte 6	Byte 7
7E5h	5Bh	00h	00h	00h	00h	00h	00h	00h

WV58MR / WH58MR → Master

COB-ID	User data							
	Byte 0 Command	Byte 1 LSB	Byte 2	Byte 3	Byte 4 MSB	Byte 5	Byte 6	Byte 7
7E4h	5Bh	Product Code (see Object 1018.2h)			00h	00h	00h	

5.6.3.3 Request revision number

Master → WV58MR / WH58MR

COB-ID	User data							
	Byte 0 Command	Byte 1	Byte 2	Byte 3	Byte 4	Byte 5	Byte 6	Byte 7

7E5h	5Ch	00h	00h	00h	00h	00h	00h	00h
------	-----	-----	-----	-----	-----	-----	-----	-----

WV58MR / WH58MR → Master

COB-ID	User data							
	Byte 0 Command	Byte 1 LSB	Byte 2	Byte 3	Byte 4 MSB	Byte 5	Byte 6	Byte 7
7E4h	5Ch	Revision number (Object 1018.3h)				00h	00h	00h

5.6.3.4 Request serial number

Master → WV58MR / WH58MR

COB-ID	User data							
	Byte 0 Command	Byte 1	Byte 2	Byte 3	Byte 4	Byte 5	Byte 6	Byte 7
7E5h	5Dh	00h	00h	00h	00h	00h	00h	00h

WV58MR / WH58MR → Master

COB-ID	User data							
	Byte 0 Command	Byte 1 LSB	Byte 2	Byte 3	Byte 4 MSB	Byte 5	Byte 6	Byte 7
7E4h	5Dh	Serial number (Object 1018.4h)				00h	00h	00h

5.6.3.5 Request Node ID

Master → WV58MR / WH58MR

COB-ID	User data							
	Byte 0 Command	Byte 1	Byte 2	Byte 3	Byte 4	Byte 5	Byte 6	Byte 7
7E5h	5Eh	00h	00h	00h	00h	00h	00h	00h

WV58MR / WH58MR → Master

COB-ID	User data							
	Byte 0 Command	Byte 1	Byte 2	Byte 3	Byte 4	Byte 5	Byte 6	Byte 7
7E4h	5Eh	Node-ID (NID)	00h	00h	00h	00h	00h	00h

5.7 Directory of objects

5.7.1 Overview of objects

The following table offers an overview of the objects of the device.

Name	Description	See page
1000h: Device Type	Device profile and encoder type	31
1001h: Error Register	Current error state of the device	31
1002h: Manufacturer Status Register	Contains the Transmit Error Counter and the Receive Error Counter	32
1003h: Pre-defined Error Field	the object stores the 8 error states that have occurred last	32
1005h: COB-ID SYNC-message	Setting of the COB ID of the SYNC object	33
1008h: Manufacturer Device Name	Device name in ASCII notation	33
1009h: Manufacturer Hardware Version	Indicates the hardware version of the device	33
100Ah: Manufacturer Software Version	Indicates the software version of the device	34
100Ch: Guard Time	Parameter for Node Guarding	34
100Dh: Life Time Factor	Parameter for Node Guarding	34
1010h: Store Parameter	Object for non-volatile storage of the settings	35
1011h: Restore Parameter	Object for restoring the factory settings	36
1014h: COB-ID Emergency message	COB ID of the Emergency object	38
1017h: Producer Heartbeat Time	Setting of the cycle time of the heartbeat timer	39
1018h: Identity Object	Contains the manufacturer number	39
1200h: Server SDO Parameter	SDO parameter	40
1800h: 1. Transmit PDO Parameter	Transmit PDO for asynchronous transfer (timercontrolled)	41
1801h: 2. Transmit PDO Parameter	Transmit PDO for synchronous transfer	42
1A00h: 1. Transmit PDO Mapping Parameter	Describes the arrangement of the objects, which are mapped in TPDO1	44
1A01h: 2. Transmit PDO Mapping Parameter	Describes the arrangement of the objects, which are mapped in TPDO2	44
2001h: Application offset	manufacturer-specific offset value (is added to the position value encoder-internally)	45
2002h: Calibrate encoder value	Set the position value to the calibration value	45
2003h: Limit speed low	Setting of the lower limit speed	46
2004h: Limit speed High	Setting of the upper limit speed	46

Name	Description	See page
5000h: Diagnosis CAN Bus error	Informs on the CAN bus errors that occurred	46
5F0Ah: Node-ID and baud rate Bus CAN	Setting of Node ID and baud rate	46
6000h: Operating Parameters	Setting of scaling and sense of rotation	48
6001h: Measurement steps per revolution (Display per revolution = APU)	Setting of the displayed measurement steps per revolution (Display per revolution = APU)	48
6002h: Overall number of measurement steps	Indicates the overall number of the system's measuring steps	48
6003h: Preset value (calibration value)	Setting the calibration value	48
6004h: Position value	position value (offset with calibration and offset value)	49
600Ch: Absolute accuracy	Raw value of position	50
6030h: Velocity value	Velocity value	50
6031h: Speed parameters	adjustment the speed parameter	50
6200h: Cycle timer	Identical with object 1800h, sub-index 5	50
6400h: Operating range (Area state register)	Indicates whether the position value is within the sewt work areas 1 and 2.	52
6401h: Work Area Low Limit	Setting of the lower limits of the work areas 1 and 2	53
6402h: Work Area High Limit	Setting of the lower limits of the work areas 1 and 2	54
6500h: Operating Status	Output of scaling and sense of rotation	52
6501h: Single-turn resolution	The physical number of measurement steps per revolution	55
6502h: Number of distinguishable revolutions	Number of revolution the encoder is able to sense	56
6503h: Alarms	indication of error states	56
6504h: Supported Alarms	indicates the alarm messages that are supported	56
6505h: Warnings	indication of warnings	57
6506h: Supported Warnings	indicates the warnings that are supported	57
6507h: Profile and Software Version	Indicates the version number of the device profile used and the version number of the encoder's firmware	56
6508h: Operating Time	Hourmeter (function is not supported)	58
6509h: Offset value	Encoder state at the time of calibration	58
650Ah: Module Identification	Indicates the manufacturer-specific offset value as well as the smallest and largest transferable position value	59
650Bh: Serial number	Indicates the serial number	60
650Dh: Absolute accuracy	provides the absolute accuracy of the encoder in bits	60
650Eh: Device functionality	provides information on device functionality	60

Table 16: Overview of objects

5.7.2 Object Description

5.7.2.1 1000h: Device Type

Object 1000h indicates the device profile number.

Subindex	00h			
Description	Information about the device profile and encoder type			
Access	ro			
PDO-Mapping	no			
Data type	UNSIGNED 32			
Default	CANopen: Singleturn: 00010196h Multiturn: 00020196h			
EEPROM	no			
Data content	Device profile -number		Gebertyp	
	Byte 0	Byte 1	Byte 2	Byte 3
	96h	01h	01h / 02h	00h

0196h (= 406d): CANopen Device Profile for Encoders

CANopen:

0001h: Absolute single-turn encoder

0002h: Absolute multi-turn encoder

5.7.2.2 1001h: Error Register

Object 1001h indicates the error state of the device.

Sub-index	00h	
Description	pending error status	
Access	ro	
PDO mapping	no	
Data type	UNSIGNED 8	
Default	0h	
EEPROM	no	
Data content	Bit	Meaning
	0	set bit indicates the occurrence of any error condition
	4	set bit indicates communication error on the CAN bus (passive or bus-off)
	7	manufacturer-specific (sensor error)
	1-3, 5-6	Not used

Faults and errors are signaled at the time of their occurrence by an emergency message

5.7.2.3 1002h: Manufacturer Status Register

Object 1002h outputs the counter readings of the “Receive Error Counter” and “Transmit Error Counter” registers. The contents of these registers provide information on the transmit faults present at the mounting site of the encoder.

Sub-index	00h			
Description	Transmit Error Counter and the Receive Error Counter			
Access	ro			
PDO mapping	no			
Data type	UNSIGNED 32			
Default	0h			
EEPROM	no			
Data content	Byte 0	Byte 1	Byte 2	Byte 3
	Receive Error Counter	Transmit Error Counter		

5.7.2.4 1003h: Pre-defined Error Field

In object 1003h, the 8 latest error states are archived (see chapter [5.5.1: Emergency Service \(EMCY\)](#)).

- the entry under sub-index 0 indicates the number of errors saved.
- The latest error status is always stored in sub-index 01h. Previous error messages “slip onwards” in their position by one sub-index.
- The whole error list is deleted by writing the value 0 in sub-index 00h.
- The entries in the error list have the format described in chapter [5.5.1: Emergency Service \(EMCY\)](#) .

Sub-index	00h			
Description	number of the error messages stored			
Access	rw			
PDO mapping	no			
Data type	UNSIGNED 8			
Default	0h			
EEPROM	yes			

Sub-index	01h-08h			
Description	error messages that occurred			
Access	ro			
PDO mapping	no			
Data type	UNSIGNED 32			

Default	0h
EEPROM	yes

5.7.2.5 1005h: COB-ID SYNC-message

The COB ID of the SYNC object is set via object 1005h.

Sub-index	00h	
Description	Defines the COB ID of the synchronization object (SYNC)	
Access	rw (writable in the "Pre-Operational" state only see chapter 5.1)	
PDO mapping	no	
Data type	UNSIGNED 32	
Default	80h	
EEPROM	yes	
Data content	Bit 31	not defined
	Bit 30	0: The device generates no SYNC message
	Bit 29	0: 11bits identifier (CAN 2.0A) 1: 29bits identifier (CAN 2.0B)
	Bit 28 ... 11	0: if bit 29 = 0 X: Bits 28 – 11 of the SYNC-COB-ID, if Bit 29 = 1
	Bit 10 ... 0	X: bits 10 – 0 of the SYNC-COB-ID

5.7.2.6 1008h: Manufacturer Device Name

Object 1008h indicates the device name. Since the latter comprises 6 or 7 data bytes, normal transfer is required for reading the SDO (see chapter 5.4.1.2: [Normal Request/Response](#)).

Sub-index	00h						
Description	Device name in ASCII notation						
Access	Const						
PDO mapping	no						
Data type	Visible_String						
Default	WV58MR / WH58MR						
EEPROM	no						
	Byte 0	Byte 1	Byte 2	Byte 3	Byte 4	Byte 5	Byte 6
	57h ("W")	56h ("V")	35h ("5")	38h ("8")	4Dh ("M")	52h ("R")	00h -

5.7.2.7 1009h: Manufacturer Hardware Version

Object 1009h indicates the hardware version.

Sub-index	00h
Description	Hardware version in ASCII notation
Access	Const

PDO mapping	no			
Data type	Visible_String			
Default	V001			
EEPROM	no			
Data content	Byte 0	Byte 1	Byte 2	Byte 3
	56h ("V")	30h ("1")	30h ("0")	31h ("0")

5.7.2.8 100Ah: Manufacturer Software Version

Object 100Ah indicates the software version of the device.

Sub-index	00h			
Description	Software version in ASCII notation			
Access	Const			
PDO mapping	no			
Data type	Visible_String			
Default	V001			
EEPROM	no			
Data content	Byte 0	Byte 1	Byte 2	Byte 3
	56h ("V")	31h ("1")	30h ("0")	30h ("0")

5.7.2.9 100Ch: Guard Time

Object 100Ch indicates the cycle time set in the master for node guarding (see chapter [5.5.2: Node Guarding](#)). The cycle time is indicated in milliseconds Value "0h" means that Node Guarding is deactivated.

Sub-index	00h			
Description	Guard Time			
Access	rw			
PDO mapping	no			
Data type	UNSIGNED 16			
Default	0h			
EEPROM	yes			

5.7.2.10 100Dh: Life Time Factor

Object 100Dh indicates the life time factor set in the master for node guarding (see chapter [5.5.2: Node Guarding](#)). Value "0h" means that Node Guarding is deactivated.

Sub-index	00h			
Description	Life Time Factor			
Access	rw			
PDO mapping	no			

Data type	UNSIGNED 8
Default	0h
EEPROM	yes

5.7.2.11 1010h: Store Parameter

Parameters are transferred into the EEPROM with this object in order to ensure that they are protected from loss of voltage. Different parameter groups are stored depending on the selection of the sub-index to be accessed. The string "Save" must be sent as data content.

Sub-index	00h
Description	indicates the largest supported sub-index
Access	const
PDO mapping	no
Data type	UNSIGNED 8
Default	4h
EEPROM	no

Sub-index	01h			
Description	Save all parameters			
Access	rw			
PDO mapping	no			
Data type	UNSIGNED 32			
Default	1h			
EEPROM	no			
Data content	Write:			
	Byte 0	Byte 1	Byte 2	Byte 3
	73h ("s")	61h ("a")	76h ("v")	65h ("e")
	Read:			
	Bit 31 ... 2	0 = reserved		
	Bit 1	0: Device does not independently store parameters		
	Bit 0	1: Device stores parameters after command		

Sub-index	02h		
Description	Save only communication parameters (1000h-1FFFh, CiA DS-301)		
Access	rw		
PDO mapping	no		
Data type	UNSIGNED 32		
Default	1h		
EEPROM	no		
Data content	Write:		
	Byte 0	Byte 1	Byte 2

	73h ("s")	61h ("a")	76h ("v")	65h ("e")
	Read:			
	Bit 31 ... 2	0 = reserved		
	Bit 1	0: Device does not independently store parameters		
	Bit 0	1: Device stores parameters after command		

Sub-index	03h			
Description	Save only application parameters (1000h-1FFFh, CiA DS-406)			
Access	rw			
PDO mapping	no			
Data type	UNSIGNED 32			
Default	1h			
EEPROM	no			
Data content	Write:			
	Byte 0	Byte 1	Byte 2	Byte 3
	73h ("s")	61h ("a")	76h ("v")	65h ("e")
	Read:			
	Bit 31 ... 2	0 = reserved		
	Bit 1	0: Device does not independently store parameters		
	Bit 0	1: Device stores parameters after command		

Sub-index	04h			
Description	Save only manufacturer-specific parameters (2000h-5FFFh)			
Access	rw			
PDO mapping	no			
Data type	UNSIGNED 32			
Default	1h			
EEPROM	no			
Data content	Write:			
	Byte 0	Byte 1	Byte 2	Byte 3
	73h ("s")	61h ("a")	76h ("v")	65h ("e")
	Read:			
	Bit 31 ... 2	0 = reserved		
	Bit 1	0: Device does not independently store parameters		
	Bit 0	1: Device stores parameters after command		

5.7.2.12 1011h: Restore Parameter

Object 1011h restores the factory settings of the device depending on the selection. The string "Load" must be sent as data content and the device reset thereafter. If the restored parameters are intended to be permanently available, they must be stored via object [1010h: Store Parameter](#).

Sub-index	00h
Description	indicates the largest supported sub-index
Access	const
PDO mapping	no
Data type	UNSIGNED 8
Default	4h
EEPROM	no

Sub-index	01h			
Description	Reset all parameters to factory settings			
Access	rw			
PDO mapping	no			
Data type	UNSIGNED 32			
Default	1h			
EEPROM	no			
Data content	Write:			
	Byte 0	Byte 1	Byte 2	Byte 3
	6Ch ("l")	6Fh ("o")	61h ("a")	64h ("d")
	Read:			
	Bit 31 ... 1	0 = reserved		
	Bit 0	1: Device permits loading of default parameters.		

Sub-index	02h			
Description	Set only communication parameters to factory settings (1000h-1FFFh, CiA DS-301)			
Access	rw			
PDO mapping	no			
Data type	UNSIGNED 32			
Default	1h			
EEPROM	no			
Data content	Write:			
	Byte 0	Byte 1	Byte 2	Byte 3
	6Ch ("l")	6Fh ("o")	61h ("a")	64h ("d")
	Read:			
	Bit 31 ... 1	0 = reserved		
	Bit 0	1: Device permits loading of default parameters.		

Sub-index	03h
Description	Set only application parameters to factory settings (6000h-9FFFh, CiA DS-406)
Access	rw

PDO mapping	no			
Data type	UNSIGNED 32			
Default	1h			
EEPROM	no			
Data content	Write:			
	Byte 0	Byte 1	Byte 2	Byte 3
	6Ch ("l")	6Fh ("o")	61h ("a")	64h ("d")
	Read:			
	Bit 31 ... 1	0 = reserved		
	Bit 0	1: Device permits loading of default parameters.		

Sub-index	04h			
Description	Set only manufacturer-specific parameters to factory settings (2000h-5FFFh)			
Access	rw			
PDO mapping	no			
Data type	UNSIGNED 32			
Default	1h			
EEPROM	no			
Data content	Write:			
	Byte 0	Byte 1	Byte 2	Byte 3
	6Ch ("l")	6Fh ("o")	61h ("a")	64h ("d")
	Read:			
	Bit 31 ... 1	0 = reserved		
	Bit 0	1: Device permits loading of default parameters.		

5.7.2.13 1014h: COB-ID Emergency message

The COB ID of the Emergency object is set via object 1014h (see chapter [5.5.1: Emergency Service \(EMCY\)](#)).

Sub-index	00h	
Description	Defines the COB ID of the Emergency object (EMCY)	
Access	rw (writable in the "Pre-Operational" state only see chapter 5.1: Telegram structure)	
PDO mapping	no	
Data type	UNSIGNED 32	
Default	80h + Node-ID	
EEPROM	yes	
Data content	Bit 31	0: EMCY object exists / is valid 1: EMCY object does not exists / is invalid
	Bit 30	Always 0b
	Bit 29	0: 11bits identifier (CAN 2.0A) 1: 29bits identifier (CAN 2.0B)

	Bit 28 ... 11	0: if Bit 29 = 0b X: Bits 28 – 11 of the EMCY-COB-ID, if Bit 29 = 1b
	Bit 10 ... 0	X: bits 10 – 0 of the EMCY-COB-ID

5.7.2.14 1017h: Producer Heartbeat Time

The cycle time “Heartbeat Time” for the heartbeat protocol is set via object 1017h. The cycle time is indicated in milliseconds

Sub-index	00h
Description	defines the cycle time of the heartbeat monitoring service
Access	rw
PDO mapping	no
Data type	UNSIGNED 16
Default	0
EEPROM	yes
Data content	0d, 10d ... 65535d (0h, Ah ... FFFFh); the numerical value corresponds to a multiple of 1 ms. Value 0h disables the service.

5.7.2.15 1018h: Identity Object

The manufacturer identification number (Vendor ID) is indicated by object 1018h.

Sub-index	00h
Description	indicates the largest supported sub-index
Access	const
PDO mapping	no
Data type	UNSIGNED 8
Default	4h
EEPROM	no

Sub-index	01h
Description	The manufacturer identification number (vendor ID) for the company SIKO GmbH allocated by the CiA
Access	ro
PDO mapping	no
Data type	UNSIGNED 32
Default	195h
EEPROM	no

Sub-index	02h
Description	Product Code (function is not supported, only compatibility entry for various configurators)

Access	ro
PDO mapping	no
Data type	UNSIGNED 32
Default	FFFFFFFFh
EEPROM	no

Sub-index	03h
Description	Revision number (function is not supported, only compatibility entry for various configurators)
Access	ro
PDO mapping	no
Data type	UNSIGNED 32
Default	FFFFFFFFh
EEPROM	no

Sub-index	04h
Description	Serial Number
Access	ro
PDO mapping	no
Data type	UNSIGNED 32
Default	1h
EEPROM	yes

5.7.2.16 1200h: Server SDO Parameter

The COB IDs for the server SDOs are indicated via object 1200h. The COB IDs cannot be changed.

Sub-index	00h
Description	indicates the largest supported sub-index
Access	const
PDO mapping	no
Data type	UNSIGNED 8
Default	2h
EEPROM	no

Sub-index	01h
Description	COB-ID Client -> Server (rx)
Access	ro
PDO mapping	no
Data type	UNSIGNED 32
Default	00000600h + Node-ID

EEPROM	no
--------	----

Sub-index	02h
Description	COB-ID Server -> Client (tx)
Access	ro
PDO mapping	no
Data type	UNSIGNED 32
Default	00000580h + Node-ID
EEPROM	no

5.7.2.17 1800h: 1. Transmit PDO Parameter

TPDO1 is used for asynchronous PDO transfer according to CiA DS-406.
The communication parameters for TPDO1 are set via object 1800h.

Sub-index	00h
Description	indicates the largest supported sub-index
Access	const
PDO mapping	no
Data type	UNSIGNED 8
Default	5h
EEPROM	no

Sub-index	01h
Description	COB ID of the PDO1
Access	rw (writable in the "Pre-Operational" state only see chapter 5.1)
PDO mapping	no
Data type	UNSIGNED 32
Default	180h + Node-ID
EEPROM	yes

Sub-index	02h	
Description	Transmission Type	
Access	rw	
PDO mapping	no	
Data type	UNSIGNED 8	
Default	FEh (254d)	
EEPROM	yes	
Data content	FEh (254d) FFh (255d) FDh (253d)	PDO has asynchronous characteristics (PDO is sent depending on the "Event Timer"). Device responds only to RTR request if RTR Bit 30 is enabled in the COB-ID.

Sub-index	03h
Description	Inhibit time (function is not supported, only compatibility entry for various configurators)
Access	ro
PDO mapping	no
Data type	UNSIGNED 16
Default	0h
EEPROM	no

Sub-index	04h (is not used, access attempt generates error message)
-----------	---

Sub-index	05h
Description	Event timer for TPD01 hard-wired (CiA DS-406) with cyclic timer 6200h
Access	rw
PDO mapping	no
Data type	UNSIGNED 16
Default	0h
EEPROM	yes
Data content	The service is disabled by writing the value 0h. the content of this object is identical with object 6200h. If the value is changed with the timer running, the change will be applied only with the next timer operation.

Sub-index	06h (is not used, access attempt generates error message)
-----------	---

5.7.2.18 1801h: 2. Transmit PDO Parameter

TPD02 is used for synchronous PDO transfer according to CiA DS-406.
The communication parameters for TPD02 are set via object 1801h.

Sub-index	00h
Description	indicates the largest supported sub-index
Access	const
PDO mapping	no
Data type	UNSIGNED 8
Default	5h
EEPROM	no

Sub-index	01h
Description	COB ID of the PDO2
Access	rw (writable in the "Pre-Operational" state only see chapter 5.1)

PDO mapping	no
Data type	UNSIGNED 32
Default	280h + Node-ID
EEPROM	yes

Sub-index	02h	
Description	Transmission Type	
Access	rw	
PDO mapping	no	
Data type	UNSIGNED 8	
Default	1h	
EEPROM	yes	
Data content	FEh (254d) FFh (255d)	PDO is sent after 1d ... 240d received SYNC messages.
	FDh (253d)	Device responds only to RTR request if RTR Bit 30 is enabled in the COB-ID.

Sub-index	03h
Description	Inhibit time (function is not supported, only compatibility entry for various configurators)
Access	ro
PDO mapping	no
Data type	UNSIGNED 16
Default	0h
EEPROM	no

Sub-index	04h (is not used, access attempt generates error message)
-----------	---

Sub-index	05h
Description	Event timer (function is not supported, only compatibility entry for various configurators)
Access	ro
PDO mapping	no
Data type	UNSIGNED 16
Default	0h
EEPROM	no

Sub-index	06h (is not used, access attempt generates error message)
-----------	---

5.7.2.19 1A00h: 1. Transmit PDO Mapping Parameter

Object 1A00h determines the objects that are mapped on the first Transmit PDO (TPD01).

Sub-index	00h
Description	number of objects mapped
Access	const
PDO mapping	no
Data type	UNSIGNED 8
Default	2h
EEPROM	no

Sub-index	01h
Description	1. Object of the PDO1 message (data byte 0 to 3)
Access	ro
PDO mapping	no
Data type	UNSIGNED 32
Default	60040020h (position value object 6004h, sub-index 00h, 32bit)
EEPROM	no

Sub-index	02h
Description	2. Object of the PDO1 message (data byte 4 + 5)
Access	ro
PDO mapping	no
Data type	UNSIGNED 16
Default	60300110h (speed object 6030h, sub-index 01h, 16bit)
EEPROM	no

5.7.2.20 1A01h: 2. Transmit PDO Mapping Parameter

Object 1A01h determines the objects that are mapped in the second Transmit PDO (TPD02).

Sub-index	00h
Description	number of objects mapped
Access	const
PDO mapping	no
Data type	UNSIGNED 8
Default	2h
EEPROM	no

Sub-index	01h
-----------	-----

Description	1. Object of the PDO2 message (data byte 0 to 3)
Access	ro
PDO mapping	no
Data type	UNSIGNED 32
Default	60040020h (position value object 6004h, sub-index 00h, 32bit)
EEPROM	no

Sub-index	02h
Description	2. Object of the PDO2 message (data byte 4 + 5)
Access	ro
PDO mapping	no
Data type	UNSIGNED 32
Default	60300110h (speed object 6030h, sub-index 01h, 16bit)
EEPROM	no

5.7.2.21 2001h: Application offset

The offset value is determined via object 2001h.

Sub-index	00h	
Description	The offset enables the shifting of a scaled value range. The offset value is added to the position value in the encoder. Positive as well as negative values are permitted. Position value = measured value + calibration value + application offset	
Access	rw	
PDO mapping	no	
Data type	SIGNED 32	
Default	0h	
EEPROM	yes	
Data content	Single-turn	-16384...16383
	4 Bit Multi-turn	-262144...262143
	8 Bit Multi-turn	-4194304...4194303
	12 Bit Multi-turn	-67108864...67108863

5.7.2.22 2002h: Calibrate encoder value

Calibration can be executed via Object 2002h.

Sub-index	00h	
Description	This object enables "zeroing" of the measured value. This serves for setting the position value to the calibration value. Position value = measured value + calibration value + application offset	
Access	wo	
PDO mapping	no	

Data type	UNSIGNED 8	
Default	0h	
EEPROM	yes	
Data content	1	Writing of the value 1h sets the position value to the calibration value.

5.7.2.23 2003h: Limit speed low

The lower value for the limit speed can be set via Object 2003h.

Sub-index	00h
Description	Lower limit speed
Access	rw
PDO mapping	no
Data type	SIGNED 16
Default	0h
EEPROM	yes
Data content	-32768...32767

5.7.2.24 2004h: Limit speed High

The upper value for the limit speed can be set via Object 2003h.

Sub-index	00h
Description	Upper limit speed
Access	rw
PDO mapping	no
Data type	SIGNED 16
Default	0h
EEPROM	yes
Data content	-32768...32767

5.7.2.25 5000h: Diagnosis CAN Bus error

A prioritized list of CAN bus errors occurring can be read via Object 5000h.

Sub-index	00h
Description	Indicates the CAN Bus errors Acknowledge, Form, CRC and Stuff Error sorted by frequency.
Access	ro
PDO mapping	no
Data type	UNSIGNED 32
Default	0h
EEPROM	no

Data content	Byte 0	Byte 1	Byte 2	Byte 3
	General Acknowledgment error	Form error	CRC error	Stuff error
	0, 1, 2, 3, 4	0, 1, 2, 3, 4	0, 1, 2, 3, 4	0, 1, 2, 3, 4

Explanation of the data content

0: No error occurring at all

4: Error occurring most frequently

5.7.2.26 5FOAh: Node-ID and baud rate Bus CAN

Node ID and baud rate of the bus can be set via Object 5FOAh.

Sub-index	00h
Description	indicates the largest supported sub-index
Access	const
PDO mapping	no
Data type	UNSIGNED 8
Default	2h
EEPROM	no

Sub-index	01h
Description	Node ID
Access	rw
PDO mapping	no
Data type	UNSIGNED 8
Default	1h (redundant encoder 2h)
EEPROM	yes
Data content	01h ... 7Fh

Sub-index	02h
Description	Baud rate of the CAN bus
Access	rw
PDO mapping	no
Data type	UNSIGNED 8
Default	5h (500kBaud)
EEPROM	yes
Data content	1: 20 kbit/s 2: 50 kbit/s 3: 125 kbit/s 4: 250 kbit/s 5: 500 kbit/s 6: 800 kbit/s 7: 1000 kbit/s

5.7.2.27 6000h: Operating Parameters

Settings of the operating parameters can be made through object 6000h.

Sub-index	00h	
Description	Operating Parameters	
Access	rw	
PDO mapping	no	
Data type	UNSIGNED 16	
Default	4h	
EEPROM	yes	
Data content	Bit 15 ... 4	not used
	Bit 3	not used
	Bit 2	1: Scaling enabled
	Bit 1	not used
	Bit 0	0: Clockwise (CW) sense of rotation I 1: Counter-clockwise (CCW) sense of rotation E

Scaling: The encoder works with the preset resolution indicator (measuring step per resolution) which can be configured by object 6001h. The scaling function cannot be disabled.

Sense of rotation I: ascending position values with clockwise (CW) encoder rotation (view on the encoder shaft)

Sense of rotation E: ascending position values with counter-clockwise (CCW) encoder rotation (view on the encoder shaft)

5.7.2.28 6001h: Measurement steps per revolution (Display per revolution = APU)

The number of measurement steps is determined via Object 6001h.

Sub-index	00h
Description	Number of measurement steps per revolution
Access	rw
PDO mapping	no
Data type	UNSIGNED 32
Default	16384d (4000h)
EEPROM	yes
Data content	1d...65535d (1h...FFFFh)

5.7.2.29 6002h: Overall number of measurement steps

Object 6002h indicates the overall number of the system's measuring steps.

Sub-index	00h
Description	Overall number of measuring units
Access	rw

PDO mapping	no	
Data type	UNSIGNED 32	
Default	Single-turn	16384
	4 Bit Multi-turn	262144
	8 Bit Multi-turn	4194304
	12 Bit Multi-turn	67108864
EEPROM	Yes	
Data content	Encoder type	With changed APU (Object 6001h)
	Single-turn	(APU*1) – 1
	4 Bit Multi-turn	(APU*16) – 1
	8 Bit Multi-turn	(APU*256) – 1
	12 Bit Multi-turn	(APU*4096) – 1

5.7.2.30 6003h: Preset value (calibration value)

Via object 6003h, the position value of the encoder can be set to a calibration value with calibration. Position value = measured value + calibration value + application offset (see chapter [4.2 Calibration](#))

Sub-index	00h		
Description	Calibration value		
Access	rw		
PDO mapping	no		
Data type	SIGNED 32		
Default	0h		
EEPROM	yes		
Data content	Encoder type	Default	With changed APU (Object 6001h)
	Single-turn	0...16383	0...((APU*1) – 1)
	4 Bit Multi-turn	0...262143	0...((APU*16) – 1)
	8 Bit Multi-turn	0...4194303	0...((APU*256) – 1)
	12 Bit Multi-turn	0...67108863	0...((APU*4096) – 1)

5.7.2.31 6004h: Position value

Object 6004h indicates the actual position value of the device.

Sub-index	00h
Description	Position value
Access	ro
PDO mapping	yes
Data type	UNSIGNED 32
Default	0h
EEPROM	no

Position value = measured value + calibration value + application offset

5.7.2.32 600Ch: Absolute accuracy

The object 600Ch provides the absolute accuracy of the encoder in bits.

Subindex	00h
Description	Raw Value (Absolute accuracy)
Access	ro
PDO-Mapping	yes
Data type	UNSIGNED 32
Default	0h
EEPROM	no

5.7.2.33 6030h: Velocity value

Velocity can be read via object 6030h.

Sub-index	00h
Description	indicates the largest supported sub-index
Access	ro
PDO mapping	no
Data type	UNSIGNED 8
Default	1h
EEPROM	no

Sub-index	01h
Description	Speed value in increments per ms (Inc/ms)
Access	ro
PDO mapping	no
Data type	SIGNED 16
Default	0h
EEPROM	no

Conversion of increments per ms in rpm

Speed [rpm] = speed value [Inc/ms] * 6000 [rpm] / 1638.4 [Inc/ms]

5.7.2.34 6031h: Speed parameters

Speed settings can be made via object 6031h.

Subindex	00h
Description	Indicates the largest supported sub-index
Access	ro

PDO-Mapping	no
Data type	UNSIGNED 8
Default	4h
EEPROM	no

Subindex	01h
Description	Speed source selector
Access	rw
PDO-Mapping	no
Data type	UNSIGNED 8
Default	02h
EEPROM	yes
Data content	02h: Object 600C raw value of position is used

Subindex	02h
Description	Integration time of speed
Access	ro
PDO-Mapping	no
Data type	UNSIGNED 16
Default	64h
EEPROM	yes
Data content	64h: 100 ms C8h: 200 ms

Subindex	03h
Description	Multiplikator
Access	rw
PDO-Mapping	no
Data type	UNSIGNED 16
Default	01h
EEPROM	yes
Data content	01h

Subindex	04h
Description	Divisor
Access	rw
PDO-Mapping	no
Data type	UNSIGNED 16
Default	01h
EEPROM	yes
Data content	01h

Velocity value [Inc/ms] = (new raw position value object 600Ch- old raw position value object 600Ch) / (Integration time [ms] object 6031h sub-index 02h * 10⁻³) * multiplier object 6031h sub-index 03h / divisor object 6031h sub-index 04h

5.7.2.35 6200h: Cycle timer

Object 6200h sets a cycle time for the output of PDO1. This value is permanently linked to object [1800h: 1. Transmit PDO Parameter](#) sub-index 05h. Timer-controlled output is active as soon as a valid cycle time has been entered and the device is operated in the operational mode. Value 0h disables the function.

Sub-index	00h
Description	Cycle timer
Access	rw
PDO mapping	no
Data type	UNSIGNED 16
Default	0h
EEPROM	yes
Data content	0d ... 65535d (0h...FFFFh)

5.7.2.36 6400h: Operating range (Area state register)

Object 6400h outputs whether the position value is within the set work areas 1 and 2.

Sub-index	00h
Description	indicates the largest supported sub-index
Access	ro
PDO mapping	no
Data type	UNSIGNED 8
Default	2h
EEPROM	no

Sub-index	01h	
Description	Status of operating range 1	
Access	ro	
PDO mapping	no	
Data type	UNSIGNED 8	
Default	0h	
EEPROM	no	
Data content	Bit 7 ... 3	not used
	Bit 2	0: Position value is within the work area 1: Position value is smaller than the limit set in Object 6401.1h

	Bit 1	0: Position value is within the work area 1: Position value is larger than the limit set in Object 6402.1h
	Bit 0	0: Position value is within the work area set 1: Position value is beyond the work area set

Sub-index	02h	
Description	Status of work area 2	
Access	ro	
PDO mapping	no	
Data type	UNSIGNED 8	
Default	0h	
EEPROM	no	
Data content	Bit 7 ... 3	not used
	Bit 2	0: Position value is within the work area 1: Position value is smaller than the limit set in Object 6401.2h
	Bit 1	0: Position value is within the work area 1: Position value is larger than the limit set in Object 6402.2h
	Bit 0	0: Position value is within the work area set 1: Position value is beyond the work area set

5.7.2.37 6401h: Work Area Low Limit

Each a lower limit can be set for one of the two work areas via Object 6401h.

Sub-index	00h
Description	indicates the largest supported sub-index
Access	ro
PDO mapping	no
Data type	UNSIGNED 8
Default	2h
EEPROM	no

Sub-index	01h		
Description	Lower limit of work area 1		
Access	rw		
PDO mapping	no		
Data type	SIGNED 32		
Default	0h		
EEPROM	yes		
Data content	Encoder type	Default	With changed APU (Object 6001h)
	Single-turn	0...16383	0...((APU*1) - 1)

	4 Bit Multi-turn	0...262143	$0 \dots ((APU * 16) - 1)$
	8 Bit Multi-turn	0...4194303	$0 \dots ((APU * 256) - 1)$
	12 Bit Multi-turn	0...67108863	$0 \dots ((APU * 4096) - 1)$

Sub-index	02h		
Description	Lower limit of work area 2		
Access	rw		
PDO mapping	no		
Data type	SIGNED 32		
Default	0h		
EEPROM	Yes		
Data content	Encoder type	Default	With maximum APU (Object 6001h)
	Single-turn	0...16383	$0 \dots ((APU * 1) - 1)$
	4 Bit Multi-turn	0...262143	$0 \dots ((APU * 16) - 1)$
	8 Bit Multi-turn	0...4194303	$0 \dots ((APU * 256) - 1)$
	12 Bit Multi-turn	0...67108863	$0 \dots ((APU * 4096) - 1)$

5.7.2.38 6402h: Work Area High Limit

Each an upper limit can be set for one of the two work areas via Object 6402h.

Sub-index	00h
Description	indicates the largest supported sub-index
Access	ro
PDO mapping	no
Data type	UNSIGNED 8
Default	2h
EEPROM	no

Sub-index	01h		
Description	Upper limit of work area 1		
Access	rw		
PDO mapping	no		
Data type	SIGNED 32		
Default	0h		
EEPROM	yes		
Data content	Encoder type	Default	With changed APU (Object 6001h)
	Single-turn	0...16383	$0 \dots ((APU * 1) - 1)$
	4 Bit Multi-turn	0...262143	$0 \dots ((APU * 16) - 1)$
	8 Bit Multi-turn	0...4194303	$0 \dots ((APU * 256) - 1)$
	12 Bit Multi-turn	0...67108863	$0 \dots ((APU * 4096) - 1)$

Sub-index	02h		
Description	Upper limit of work area 2		
Access	rw		
PDO mapping	no		
Data type	SIGNED 32		
Default	0h		
EEPROM	yes		
Data content	Encoder type	Default	With changed APU (Object 6001h)
	Single-turn	0...16383	$0 \dots ((APU * 1) - 1)$
	4 Bit Multi-turn	0...262143	$0 \dots ((APU * 16) - 1)$
	8 Bit Multi-turn	0...4194303	$0 \dots ((APU * 256) - 1)$
	12 Bit Multi-turn	0...67108863	$0 \dots ((APU * 4096) - 1)$

5.7.2.39 6500h: Operating Status

The object 6500h indicates the settings programmed with object 6000h.

Sub-index	00h	
Description	Operating Status	
Access	ro	
PDO mapping	no	
Data type	UNSIGNED 16	
Default	4h	
EEPROM	no	
Data content	Bit 15 ... 4	not used
	Bit 3	not used
	Bit 2	0: Scaling disabled 1: Scaling enabled
	Bit 1	not used
	Bit 0	0: Clockwise (CW) sense of rotation I 1: Counter-clockwise (CCW) sense of rotation E

5.7.2.40 6501h: Single-turn resolution

Object 6501h indicates the physical number of measurement steps per revolution.

Sub-index	00h
Description	Physical resolution
Access	ro
PDO mapping	no
Data type	UNSIGNED 32
Default	16384d (4000h)
EEPROM	no

5.7.2.41 6502h: Number of distinguishable revolutions

Object 6502h indicates the number of resolutions the encoder is able to sense.

Sub-index	00h	
Description	Physical resolution	
Access	ro	
PDO mapping	no	
Data type	UNSIGNED 16	
Default	Single-turn	1
	4 Bit Multi-turn	16
	8 Bit Multi-turn	256
	12 Bit Multi-turn	4096
EEPROM	no	

5.7.2.42 6503h: Alarms

Object 6503h indicates other device-specific alarm messages in addition to the errors reported via the Emergency message. In the case of an error, the associated bit is set to 1.

Sub-index	00h	
Description	Alarm messages	
Access	ro	
PDO mapping	no	
Data type	UNSIGNED 16	
Default	0h	
EEPROM	no	
Data content	Bit 15 ... 14	Not used
	Bit 13	0: Position value within work area 2 1: Position limit 2 exceeded or undershot (Work area 2)
	Bit 12	0: Position value within work area 1 1: Position limit 1 exceeded or undershot (Work area 1)
	Bit 11 ... 1	Not used
	Bit 0	0: Position value valid 1: position value invalid

5.7.2.43 6504h: Supported Alarms

This Object 6504h indicates the alarm messages that are supported. The relevant bits are set.

Sub-index	00h	
Description	Supported alarm messages	
Access	ro	
PDO mapping	no	

Data type	UNSIGNED 16	
Default	3001h	
EEPROM	no	
Data content	Bit 15 ... 14	Not used
	Bit 13	Position limit 2 error
	Bit 12	Position limit 1 error
	Bit 11 ... 1	Not used
	Bit 0	position error

5.7.2.44 6505h: Warnings

The warnings displayed via Object 6505h indicate that tolerances of internal encoder parameters have been exceeded. However, unlike with alarm messages, the position value can be valid in case of a warning.

Sub-index	00h	
Description	Warnings	
Access	ro	
PDO mapping	no	
Data type	UNSIGNED 16	
Default	0h	
EEPROM	no	
Data content	Bit 1 ... 15	Not used
	Bit 0	0: Speed ok 1: maximum speed exceeded or limit speed set exceeded or undershot (2003h: Limit speed low)

5.7.2.45 6506h: Supported Warnings

The Object 6506h indicates the warnings that are supported.

Sub-index	00h	
Description	Supported warnings	
Access	ro	
PDO mapping	no	
Data type	UNSIGNED 16	
Default	0001h	
EEPROM	no	
Data content	Bit 1 ... 15	Not used
	Bit 0	Speed warning

5.7.2.46 6507h: Profile and Software Version

The object 6507h indicates the encoder profile used (CANopen Device profile for encoders) and the version number of the firmware state.

Sub-index	00h			
Description	Profile and Software Version			
Access	ro			
PDO mapping	no			
Data type	UNSIGNED 32			
Default	01000302h			
EEPROM	no			
	Profile Version		Software version	
	Byte 0 (LSB)	Byte 1	Byte 2	Byte 3 (MSB)
	02h	03h	01h	00h

5.7.2.47 6508h: Operating Time

The operating hours can be indicated via object 6508h. This function is not supported

Sub-index	00h
Description	Hourmeter
Access	ro
PDO mapping	no
Data type	UNSIGNED 32
Default	FFFFFFFFh
EEPROM	no

5.7.2.48 6509h: Offset value

The Object 6509h indicates the difference between encoder value and the scaled and offset against

preset and application offset position value.

Sub-index	00h
Description	Encoder state at the time of calibration
Access	ro
PDO mapping	no
Data type	SIGNED 32
Default	0h
EEPROM	yes

5.7.2.49 650Ah: Module Identification

Object 650Ah Indicates the manufacturer-specific offset value as well as the smallest and largest transferable position value.

Sub-index	00h
Description	indicates the largest supported sub-index
Access	ro
PDO mapping	no
Data type	UNSIGNED 8
Default	3h
EEPROM	no

Sub-index	01h
Description	Manufacturer-specific offset value
Access	ro
PDO mapping	no
Data type	SIGNED 32
Default	0h
EEPROM	no

Sub-index	02h
Description	Smallest transferable position value
Access	ro
PDO mapping	no
Data type	SIGNED 32
Default	0h
EEPROM	no

Sub-index	03h		
Description	Largest transferable position value		
Access	ro		
PDO mapping	no		
Data type	SIGNED 32		
EEPROM	yes		
Data content	Encoder type	Default	With maximum APU (Object 6001h)
	Single-turn	16383	$65534 ((65535 * 1) - 1)$
	4 Bit Multi-turn	262143	$1048559 ((65535 * 16) - 1)$
	8 Bit Multi-turn	4194303	$16776959 ((65535 * 256) - 1)$
	12 Bit Multi-turn	67108863	$268431359 ((65535 * 4096) - 1)$

5.7.2.50 650Bh: Serial number

Object 650Bh provides the serial number of the encoder. The serial number is composed of the imprinted serial number and a suffixed 1 or 2 to enable unambiguous identification of each encoder.

Sub-index	00h
Description	Serial number
Access	ro
PDO mapping	no
Data type	UNSIGNED 32
Default	0h
EEPROM	yes

5.7.2.51 650Dh: Absolute accuracy

The object 650Dh provides the absolute accuracy of the encoder in bits.

Subindex	00h
Description	Absolute accuracy
Access	ro
PDO-Mapping	no
Data type	UNSIGNED 8
Default	08h
EEPROM	no

5.7.2.52 650Eh: Device functionality

Speed settings can be made via object 6031h.

Subindex	00h	
Description	Device functionality	
Access	ro	
PDO-Mapping	no	
Data type	UNSIGNED 32	
Default	CANopen: 0002h (class 2)	
EEPROM	no	
Data content	Bit 15 ... 8	not used
	Bit 7 ... 6	00: CANopen Safety 01 ... 11: not used
	Bit 5	0: Safety is not supported 1: Safety is supported
	Bit 4	not used
	Bit 3	0: normal resolution 1: high resolution

	Bit 2 ... 0	000: reserved 001: class C1 010: class C2 011: class C3
--	-------------	--



SIKO GmbH

Weihermattenweg 2
79256 Buchenbach

Phone

+ 49 7661 394-0

Fax

+ 49 7661 394-388

E-Mail

info@siko-global.com

Internet

www.siko-global.com

Service

support@siko-global.com